

## ADAPTER PLATE - PLAQUE D'ADAPTATION

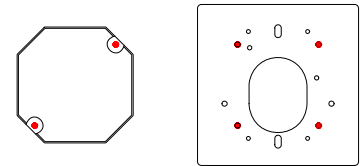

- ① Fix the bracket to the wall.  
(use appropriate anchors depending on the type of wall).

Fixez le support au mur.  
(utilisez des ancrages appropriés selon le type de mur.)

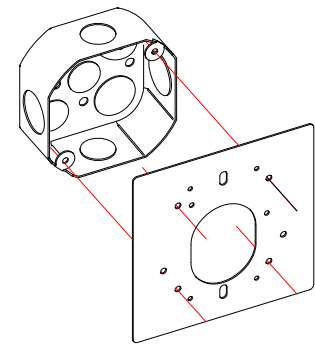
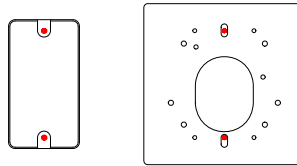
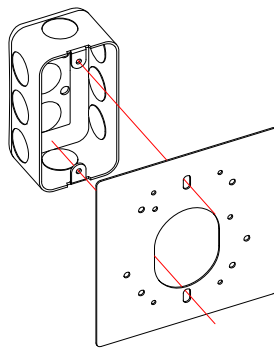
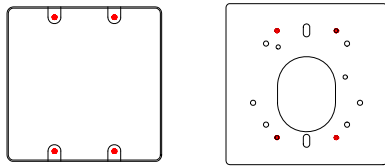
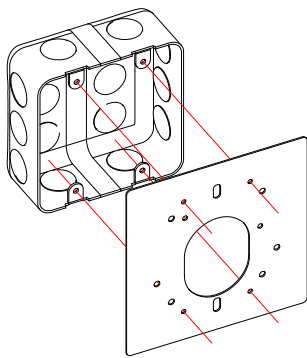
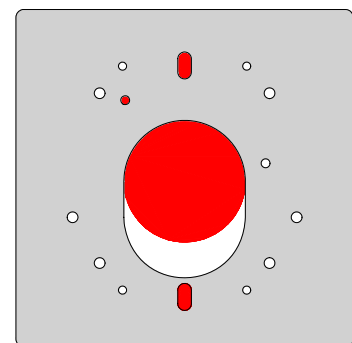
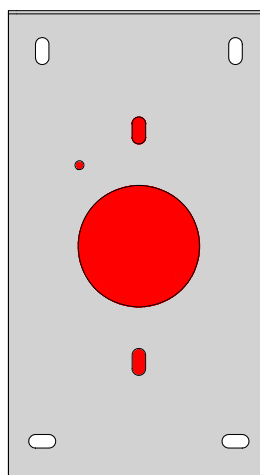

- ② Connect the wires cables following the sketch.  
To inspection the electrical connections remove the luminaire from the junction box.

-----  
Connectez les câbles suivant le dessin.  
Pour inspecter les connexions électriques, retirez le luminaire de la boîte de jonction.

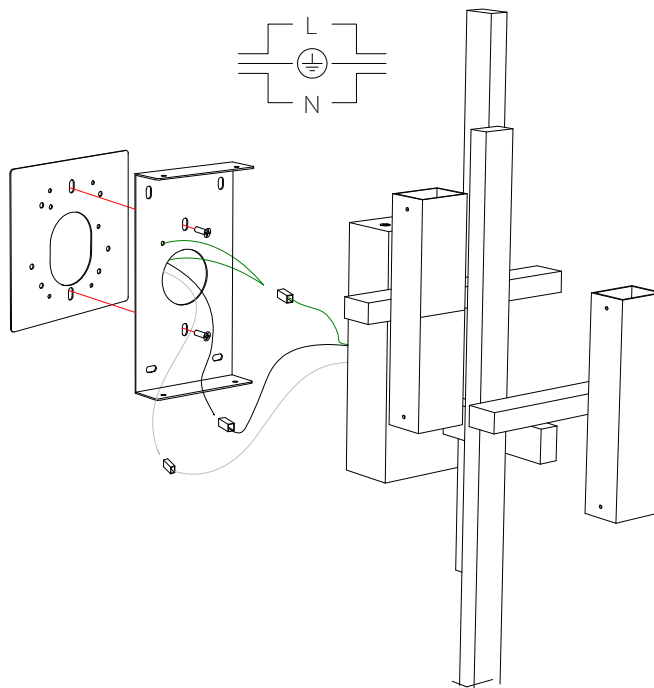

- ③ Fix the lamp to the bracket with the screws provided.  
Fix the crystal di sers in the proper position following the instruction attached.

-----  
Fixez la lampe au support avec les vis fournies.  
Fixes les diuseurs en cristal dans la bonne position en suivant les instructions jointes.

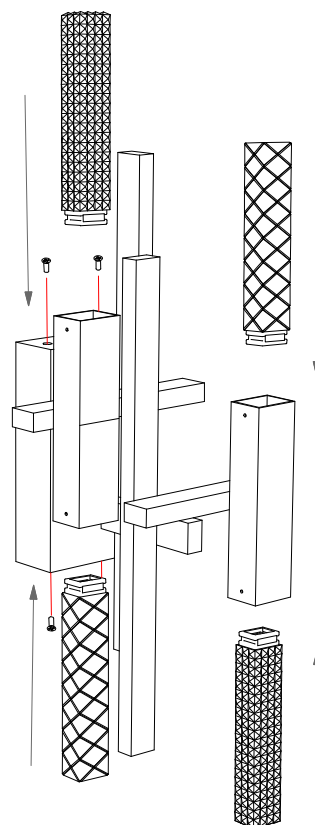



1. KIT



2. Inserire il diffusore di vetro nel suo scompartimento, applicando una leggera pressione sui lati.  
*Insert the glass diffuser into the proper space, applying a little pressure in the sides.*



3. Stringere il grano sul lato sinistro con la chiave fornita.  
*Screw the grain on the left side with the provided Allen Key.*



4. Stringere il grano sul lato destro.  
*Screw the grain on the right side.*



5. Stringere il grano sul lato posteriore.  
*Screw the grain on the back.*



6. Verificare che il vetro sia fissato bene, dopodichè ripetere i cinque passaggi per tutti i vetri.  
*Check that the glass diffuser is well fastened, then repeat the five steps for all the glasses.*



## 25W Constant Current Mode LED Driver



### DIMMING OPERATION

※ 3 in 1 dimming function

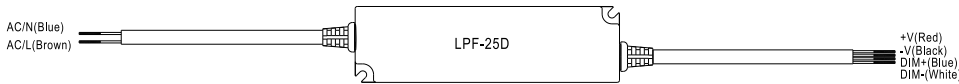

- Output constant current level can be adjusted by applying one of the three methodologies between DIM+ and DIM-: 1 ~ 10VDC, or 10V PWM signal or resistance.
- Direct connecting to LEDs is suggested. It is not suitable to be used with additional drivers.
- Dimming source current from power supply: 100μA (typ.)

◎ Applying additive 1 ~ 10VDC

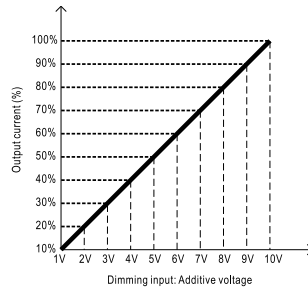
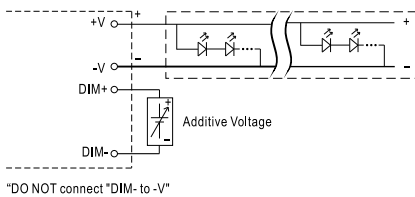

◎ Applying additive 10V PWM signal (frequency range 100Hz ~ 3KHz):

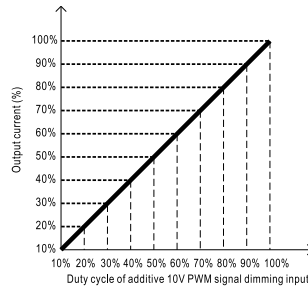
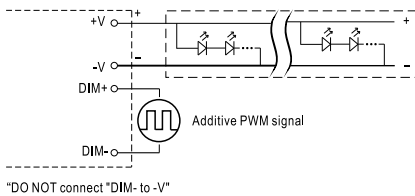

◎ Applying additive resistance:

